

# **The effectiveness of a credit financing model and the potential of regional economy for micro and small business enterprises in South Sumatera, Indonesia**

**Abdul Basyith**

*University of Muhammadiyah, Palembang, Indonesia*

*basyith\_feump@yahoo.com*

**Fatimah**

*University of Muhammadiyah, Palembang, Indonesia*

**Muhammad Idris**

*University of Muhammadiyah, Palembang, Indonesia*

## **Abstract**

This research aims at examining (1) the effectiveness of a credit financing model, and (2) the potential of regional economy for micro and small business enterprises in South Sumatera, Indonesia. Involving 748 respondents from 14 regions in South Sumatera, this study employs a matrix analysis and ordinary least square. First, according to the matrix analysis of descriptive statistic, there are three industries that potentially have higher productivity in supporting the regional economy in South Sumatera, Indonesia. Those three potential industries are food, beverages and tobaccos industry, other processing industry, and textile, clothes and leather industry. OKU Timur Regency, MUBA Regency, and OKU Selatan Regency are the regions having higher productivity and potential in the sector of food, beverages, and tobaccos industry. Palembang City, Banyuasin Regency and Muara Enim Regency are the regions having high productivity and potential in the sector of other processing industry. Ogan Ilir Regency, Pagaram City, and OKU Induk Regency are the three regions having high productivity and potential in the sector of textile, clothes, and leather industry. Hence, the local and regional governments should be more responsive to stimulate all those regions in the three industries. Second, the result also reveals that raw materials, local products with local characteristics, the guarantee of raw material availability, and economic profitability have a significant impact on micro and small business enterprises' productivity. Furthermore, the result supports the notion that a potential product of one region

### *Citation:*

Basyith, A. et al. (2016). The effectiveness of a credit financing model and the potential of regional economy for micro and small business enterprises in South Sumatera, Indonesia. *Global Business and Economics Research Journal*, 5(2): 1-16.

is determined by the local contents of raw materials; the more local contents of one product, the higher the potentiality of that product.

*Keywords:* micro and small business enterprises, productivity, credit financing, potential sector

## 1. Introduction

Small business sector has a very significant role in the growth of Indonesian economy. Not only does the small business sector have an important role in creating jobs, it can also improve the quality of human resources, improve the entrepreneurial culture, develop creativity and, create other business opportunities. Furthermore, the small business sector has been able to prove its resistance to crisis and its survival in difficult economic conditions. Yet, the main problem often faced by the small business sector is the lack of access to market information and technology, the lack of human resources, and the lack of access to capital.

Although various attempts have been made by financial institutions and government agencies to minimize the existing gaps, the small business sector still encounters difficulties in obtaining loans. A loan for small business sector is relatively small and not attractive to financial institutions. Higher collaterals are required to obtain the loan. Those barriers may be due to the lack of understanding on the small business sector institution-based businesses (small and medium knowledge-based businesses). Moreover, the lack of flexibility on the terms and conditions of the loan to the small business sector is a source of problems for the small business sector. To overcome this, the government through the ministry has issued various policies aimed at helping the micro and small enterprises sector to access to capital. As a result of the government regulation, banks are required to allocate 20% of their funds for micro and small business sectors.

Microfinance institutions in Indonesia are categorized into two categories: formal (banks and non-banks) and non-formal such as Baitul Maal Wat Tamwil (BMT). The similarity between BMT and cooperative as non-formal microfinance institution is that the business is operated by the principle of sharing and growing in order to support the small business enterprises and hence the goal of social economic equality can be achieved. In contrast to cooperative using interest rates, BMT is operated based on Islamic law in which no interest rates are permitted (profit sharing principle). Further, BMT also receives funds from Islamic sources such as alms and donations (*zakat*, *sadaqah* and *infaq*). Microfinance institutions will be hereinafter referred to as MFI and the micro and small business sector will be called

SMEs. SMEs and MFIs have correlation to one another, where MFIs are the main tools that can be used by SMEs in meeting their capital requirements. However in the financing process, MFIs require the SMEs to meet their financing criteria which are known as 5Cs (character, capital, collateral, capacity and condition of economic). On the other hand, capital and collateral are the most prominent obstacles in obtaining funds from the MFI, and this leads to ineffectiveness of MFI credit financing system. This policy, which emphasizes on the capital and collateral, is inappropriate for SMEs that mostly have lower capital and limited collateral. Therefore, the MFI would need to make measurements of other criteria that are specifically made for lending to SMEs. As the first step, the MFI must have criteria that need to be added in the assessment of lending to SMEs, such as in terms of the criteria of product, sector and of other criteria.

In terms of product criteria, MFIs can add a requirement that the SMEs have to produce an eminent product in their industry sector so that the financing opportunity is higher. In terms of the company's criteria, MFI could select a firm that has a promising future in which this company has to have an outstanding business prospect. Outstanding firms are companies that have the potential in terms of market access (both local market and international market). Therefore, to ease the financing process for SME and MFI, mapping of eminent product and outstanding business sectors is required.

The measure of success for MFI in proving the financing to SMEs is lower than the non-performing loan. However, this measure is only a financial measure for the MFI. Other than financial measure, MFI should also emphasize the social responsibility measure. This can be done if MFI also have a sense of responsibility towards the success of SMEs on the capital provided. During this time, some MFIs provide guidance to SMEs which obtain credit from the MFIs. However, a fostering action by MFIs is only done to ensure that the capital borrowed can be paid on time. Therefore, the fostering model also needs to be revised.

Most SMEs have limitations in terms of capital and collateral, and some of SMEs that have the potential of products or businesses sometimes do not have the collateral that can be used to obtain capital. To solve this problem, the government has taken various actions; one of the actions is issuing a regulation which stipulates that no collateral is required to acquire a loan below IDR 50,000,000.-. However, the policy on lending without collateral (1) is not performed entirely by some MFIs; in some areas in South Sumatra, SMEs still require a collateral to obtain loan that is equal to or less than IDR 50,000,000, -, (2) gives more

problems to MFI as it increases bad debts (higher non-performing loan), affecting the financial position of the MFI itself (Basyith et al., 2014).

Not only did banks ask collateral but they also asked higher collateral compared to the required financing proposed. As most small businesses have insufficient collateral, there was a financing gap between microfinance institutions and small business enterprises (Susilo et al., 2012). Furthermore, Hasbullah et al. (2014) stated that financial institutions provide the lowest support to the small business enterprises' development. Moreover, Lantu et al. (2016) affirmed that external supports have no significant impact on the small business enterprises' capability in developing their business, while financing and partnership play an important role in SME's business capability. In addition, the position of the MFI determines the competitiveness. SME also has its own preferences in choosing MFIs. Preferences can derive from MFI location, ease of lending by MFIs, MFI lending rates, and MFIs sales hospitality. With regard to the research gaps, this study attempts to investigate an effective model of credit financing and the regional economic potentiality for micro and small business enterprises in South Sumatera, Indonesia.

## **2. Literature Review**

There are some advantages of SMEs' existence. One of the advantages is that the SMEs can tap the most non-formal labors. It strengthens the national economy by productively absorbing workers. Total factor productivity and labor productivity can be used as efficiency measures in the small business sector and this productivity varies across industries. However, having advantages does not guarantee that all else will be easy to be acquired by SME, for example lack of access to effective financing, lack of managerial skills, equipment and technology, information, regulatory issues, and access to international markets (Aryeetey et al., 1994). Therefore, it disrupts the SMEs growth. In addition, limited marketing experience, poor quality control of product, and lower product standardization contribute to the lower engagement of SMEs in the international market (Aryeetey et al., 1994). Moreover, lack of fostering, training and advisory services add more problems as there are still skills gap in the SME sector (Kayanula & Quartey, 2000). Due to those constraints, most of SMEs' owners prefer to work as wage workers in some other sectors rather than managing the business which has no certainty of survival (Basyith et al., 2014).

The main distinction that distinguishes SMEs is labor characteristics, ownership characteristics and industrial uniqueness (Fisher & Reuber, 2000). As mentioned previously,

SMEs are more labor intensive and their lower capital costs are associated with job creation (Schmitz, 1995). SMEs are mostly owned by a single person or a group of family members and they are mostly managed by female (housewives). SMEs are mostly in the sector of food production process from the local crops. Given the fact most SMEs are managed by housewives and since the financing institutions require collaterals, it is clear that they will have lower chances of accessing finance as most assets are commonly under the name of the head of the family, particularly the men (Aryeetey et al., 1994; Abor & Biekpe, 2006). Further, members of the family involved in the business apparently tend to be unpaid labors.

Most small business enterprises in developing countries, in particular Indonesia, are in the sectors of retailing, trading, or manufacturing (Fisher & Reuber, 2000). This study involves small business enterprises in the manufacturing sector, which are categorized into five groups: (1) food, beverages and tobaccos sector, (2) textile, clothes and leather sector, (3) woods and household furniture sector, (4) paper, printing and publishing sector, and (5) other manufacturing sector. This manufacturing industry depends on the availability of raw materials, production process, local consumers' needs and the level of development of the export markets. If there are lacks of those factors, the survival of SMEs in this sector is vulnerable. Although financial support is important in supporting small business survival, identifying a product and a market is also important (Green et al., 2002). However, some studies have shown that a large number of small enterprises fail because of non-financial reasons such as lack of access to appropriate technology and weak institutional capacity and lack of management skills and training (Aryeetey et al., 1994; Kayanula & Quartey, 2000).

Even though small business has been acknowledged as the main contributor to economic growth and job creation, the fact that most of micro and small business enterprises encounter difficulties in terms of human resources, raw materials, and management is prevalent. Steiner & Olaf (1988) stated that small business failure is a common occurrence; as much as 70% of small business failed to survive. In addition, Steiner & Olaf (1988) affirmed that an experienced owner/manager, specialized knowledge of manufacturing process, access to adequate financial resources, higher competitive advantages, and a well-developed strategy are important for small businesses to prosper. Moreover, other than internal factors that contribute to the small businesses' survival, the external factors also have a major contribution to the success. One of the external factors is the government's supports (Hadjimanolis, 1999; Ravikiran & Vittal, 2015).

Further, the lack access to capital is viewed as a major constraint of SMEs' survival (Pettit & Singer, 1985; Keasey & Watson, 1987; Lader, 1996). Pettit & Singer (1985), Keasey & Watson (1987) have identified the main cause of the decline of small business growth, which is financial problems. Financing micro and small businesses is difficult because of the problem of information asymmetry. The high cost for collecting information by creditors to determine whether or not the SME has a good business prospect is inevitable. An innovative way to solve this problem is by increasing the credit available to SMEs through an increased use of technology and the introduction of precise credit scoring provided by financing institutions (Brewer, 2007).

It is also expressed by Ang (1991) and Berger & Udell (1998) that in addition to having different characteristics from large businesses, small and micro businesses also have problems of financial management and financial access. Further, Carpenter & Petersen (2002) and Beck & Demirgüç-Kunt (2006) also stated that small business growth is often limited by financial constraints internally and that access to capital is a major constraint to the growth of micro and small businesses, in which legal institutions and finance play an important role in solving this problem. Then, the innovative financial instrument to facilitate micro and small businesses in accessing financing is important. Additionally, the limited availability of financial resources may be due to the different scale of economies of small businesses in which larger businesses have the priority in financing over the smaller ones (Levy, 1993).

Not only have some studies been conducted to find out factors affecting the ability to pay the loan (Gine & Karlan, 2008; Karlan, 2007), but also to find out whether the loan had an impact on the profitability and survival of SMEs (Basyith et al., 2014, Banerjee et al., 2009). The study found that the loans give a short-term impact on the profitability of SMEs but not for the long term. This is caused by the lack of guidance provided by the MFI. Although fostering is provided, it is only limited to formal guidance aimed at ensuring that SMEs are able to repay the loan on time and to repay the principal in due date.

Furthermore, several studies have also shown that financing has a positive impact on the growth of SMEs, especially businesses that are most in need of financing (Demirgüç-Kunt & Maksimovic, 1998; Rajan & Zingales, 1998; Beck et al., 2005; Beck et al., 2006; Beck et al., 2008). Not only can the financing overcome liquidity difficulty, it can also improve business production activities that ultimately have a positive impact on the profitability of the business (Wurgler, 2000; Love, 2003; Banerjee & Duflo, 2004). A convenient access to finance may

stimulate SMEs to become more dynamic and innovative (Klapper et al., 2006), result in higher economies of scale which can be increased by having greater investment opportunities (Beck et al., 2006), provide many options for SMEs to choose a portfolio that is more efficient (Claessens & Laeven, 2004), and to provide opportunities for SMEs to diversify business risks (Beck et al., 2006).

On the other hand, financial institutions in developing countries have limited access to information on the feasibility and the ability of borrowers to repay the loan. The tools used by developed countries to detect it (such as credit scoring) cannot simply be used and applied in developing countries. When the information available is not formally provided, then the feasibility of such information depends on the local social networks' information (Portes, 1998; Smith-Doerr & Powell, 2005). In the end, the main obstacle faced by MFIs is how to overcome information asymmetry between MFI and SME. Although more than half of the world's population has limited access to financial institutions (Beck et al., 2008; Chaia et al., 2009), the potential market for MFIs is very substantial.

### **3. Research Methodology**

#### **3.1 Data**

The data used in this research are related to SMEs and MFIs. The primary data were obtained using a structured questionnaire, semi-structured focus group discussion (FGD), and interviews. The classification of the SMEs will be based on the classification used by the Ministry of Cooperatives and SMEs and Bank Indonesia in 2008. The MFIs are divided into two: formal and non-formal. This study will use formal MFIs, namely banks and non-bank.

The population in this study includes all SMEs and MFIs in the Province of South Sumatra. South Sumatra Province consists of four autonomous cities and 12 counties. MSE in South Sumatra consist of formal (registered) and non-formal SMEs (not registered). Formal MSE can be obtained from the Ministry of Cooperatives and SMEs as well as the relevant ministry. However, at the time this proposal is made, the number of non-formal SMEs in South Sumatra could not be precisely identified. The total population in this study is a population that is not limited (there are no exact data about the number of micro and small enterprises of processing industry in South Sumatra because most of them are not registered legally in the Department of Commerce and the Department of Cooperatives and Micro and Small).

The sampling design used was multistage sampling design, where a design sample is done through several stages (Levy & Lemeshow, 2008). Multistage sampling design is a complex form of cluster sampling. Cluster sampling is a form of sampling which divides the population into groups (clusters). Then, one or more of the groups (clusters) will be selected randomly and each unit (element) in each cluster will also be selected randomly as the sample. The steps to be taken in the design of the sample include: (1) the selection of cities and counties in South Sumatra by using cluster sampling, (2) the selection of the location of each city and county in South Sumatra by using judgmental sampling criteria, which are (a) the capital of the cities and counties in South Sumatra, (b) having a number of SMEs and most MFIs, (3) the selection of units (elements) of each location of cities and counties selected using random sampling.

This study involved 748 respondents who came from 12 cities and regencies in South Sumatra: Banyuasin (50 respondents), OKU District Parent (50 respondents), Lubuk Linggau (50 respondents), Pagaralam (50 respondents), Palembang (100 respondents), Lahat (50 respondents), District MUBA (50 respondents), OKI (48 respondents), Regency of East OKU (50 respondents), District PALI ( 50 respondents), District of South OKU (50 respondents), Muara Enim (47 respondents), Musi Rawas (53 respondents), and Ogan Ilir (50 respondents).

### **3.2 Variables**

The variables employed in this study for matrix analysis derive from previous studies such as productivity, the local contents of raw materials, and product for exports. The variables for an ordinary least square method (OLS) are the local contents of raw materials (X1), the competitive advantage (X2), the product reflecting local characteristics (X3), the guarantee of raw material availability (X4), the economic value added (X5), economically profitable (X6), environment conservation (X7) and productivity (Y).

### **3.3 Method of Analysis**

The method analyses employed are matrix analysis and an ordinary least square (OLS). For matrix analysis, the statistic descriptive of the data is derived. The ordinary least square (OLS) for this study is:

$$Y_i = \alpha + b_{1i}X_{1i} + b_{2i}X_{2i} + b_{3i}X_{3i} + b_{4i}X_{4i} + b_{5i}X_{5i} + b_{6i}X_{6i} + b_{7i}X_{7i} + e_i$$

*Notes: the local contents of raw materials (X1), the competitive advantage (X2), the product reflecting local characteristics (X3), the guarantee of raw material availability (X4), the economic value added (X5), economically profitable (X6), environment conservation (X7), productivity (Y), and error terms (e).*



#### 4. Findings and Discussion

This section is divided into two parts: (a) an effective credit financing model, and (b) the potential industry sectors supporting the regional economic.

##### 4.1 An effective credit financing model

The findings reveal that an effective credit financing model should include outside parties to control and foster the success and the survival of micro and small business enterprises. The initial model proposed for effective credit financing is depicted in Figure 1.

Figure 1. An effective of credit financing model

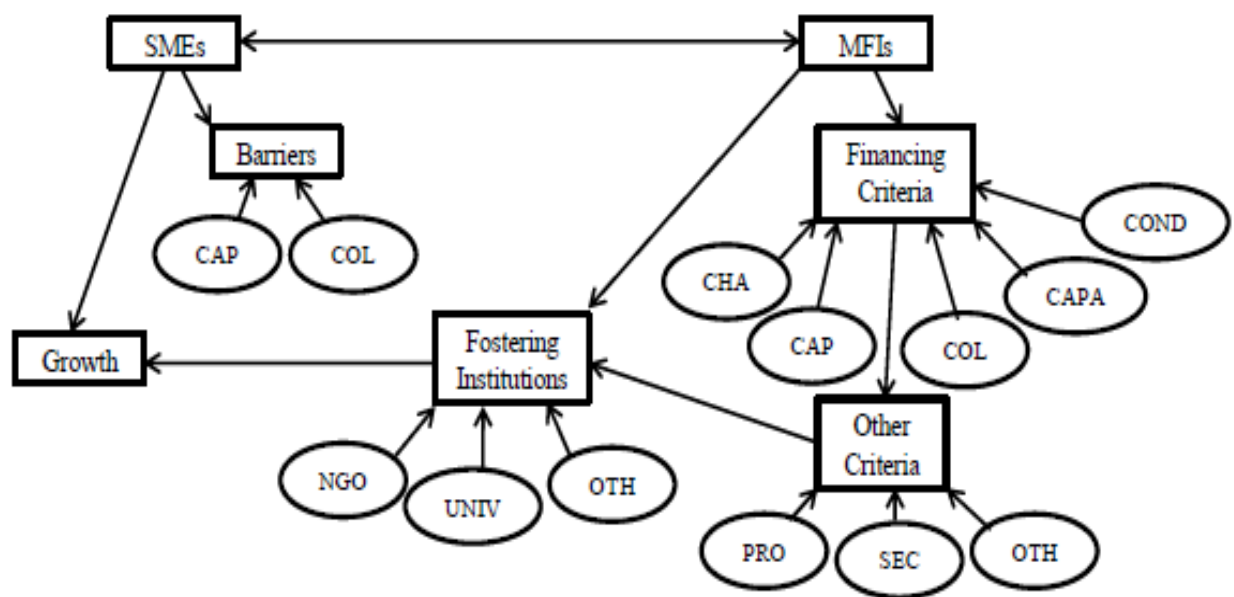

Figure 1 is explained as follows:

1. MFI lends the fund to the SMEs.
2. MFI conducts an assessment of the 5Cs criteria (CHA stands for characteristics, CAP stands for capital, COL stands for collateral, CAPA stands for capacity and COND stands for condition), and then forwards the assessment result to the Credit Guarantee Institution (Fostering Institutions) to assess other aspects (aspects of potential products and potential aspects featured SMEs). These fostering institutions are non-governmental organizations (NGOs), universities (UNIV) or other institutions (OTH).
3. Having obtained the results of the assessment of MFIs from credit guarantee institutions (fostering institutions), then it can be decided whether SME deserve financing.

4. The eligible SMEs will be financed and supervised by an independent agency/private (fostering institutions). The fostering institutions can be established as independent institutions that cooperate with the government and are supervised by relevant state agencies.
5. The fostering institutions will foster the development of SME financed by the MFI. The source of income of the fostering institutions can come from MFIs. MFIs can pay the fees for the use of fostering services by the private fostering institutions, so that the private fostering institutions can work professionally. It would be different if the fostering institution is a nonprofit institution. It is most likely that the nonprofit fostering institutions will not work optimally. The mechanism service fee to be paid to fostering institutions by the MFI is the tariff system per customer monthly/yearly.
6. The fostering institutions have to provide a complete report for MFI with regard to unpaid loans and the size of the SMEs after getting financed. Hence, the fostering institution can also create a benchmarking of credit scoring success rate.
7. SME should report to the MFI and fostering institutions with regard to their business development. So, MFIs and fostering institutions can take an appropriate measure if there are problems.
8. The function of the fostering institutions is to provide the feasibility assessment; the fostering institutions can also provide assurance to the SME that does not have sufficient collateral.

#### ***4.2 The potential industry sector supporting the regional economic***

The matrix analysis results reveal that there are three industries that potentially have high productivity in supporting the regional economy in South Sumatera, Indonesia. Those three potential industries are Food, Beverages and Tobaccos Industry, Other Processing Industry, and Textile, Clothes and Leather Industry. OKU Timur Regency, MUBA Regency and OKU Selatan Regency have high productivity and potential in the sector of Food, Beverages and Tobaccos Industry. Palembang City, Banyuasin Regency and Muara Enim Regency have high productivity and potential in the sector of Other Processing Industry. Meanwhile, Ogan Ilir Regency, Pagaralam City and OKU Induk Regency have high productivity and potential in the sector of Textile, Clothes and Leather Industry. The matrix analysis is shown in Table 1.

The result of the ordinary least square (OLS) analysis reveals that raw materials (X1), local products which have characteristics of local area (X3), the guarantee of raw material availability (X4) and economically profitable (X6) have a significant impact on micro and

small business enterprises' productivity. The result is in line with the notion that a potential product of one region is determined by the local contents of raw materials; the more local contents of one product, the higher the potentiality of that product. Limited marketing experience, poor quality control of product, lower product standardization contribute to the low engagement of SMEs in the international market (Aryeetey et al., 1994). The fact that most of the micro and small business enterprises encounter difficulties in human resources, raw materials, and management is prevalent.

Table 1. Matrix Analysis of Potential Sectors for Micro and Small Business Enterprises in South Sumatera, Indonesia

Industry	Food, Beverages and Tobacos Industry	Other Processing Industry	Textile, Clothes and Leather Industry
Regency/City	OKUT	Palembang	Ogan Ilir
Regency/City	MUBA	Banyuasin	Pagaralam
Regency/City	OKUS	Muara Enim	OKU Induk

As stated by Steiner & Olaf (1988), small business failure is a common occurrence; 70% of small business failed to survive. In addition, Steiner & Olaf (1988) proposed that an experienced owner/manager, specialized knowledge of manufacturing process, an access to adequate financial resources, higher competitive advantage and a well-developed strategy are important for small businesses to prosper. Moreover, other than internal factors that contribute to the small businesses' survival, external factors also significantly contribute to the success. Further, the result also supports the notion that the main distinction that distinguished SMEs is labor characteristics, ownership characteristics and industrial uniqueness (Fisher & Reuber, 2000). As most of small business enterprises in developing countries, particularly Indonesia, are in the sectors of retailing, trading, or manufacturing (Fisher & Reuber, 2000). This study only employs the manufacturing sector of small business enterprises, categorized into five groups; (1) food, beverages and tobaccos sector, (2) textile, clothes and leather sector, (3) woods and household furniture sector, (4) paper, printing and publishing sector, and (5) other manufacturing sector. This manufacturing industry depends on the availability of raw materials, production process, local consumers' needs and the level of development of the export markets. If there are lacks of the factors, then the survival of SMEs on this sector is vulnerable. In conclusion, although financial support is important for

supporting small businesses' survival, identifying a product and a market is also important (Green et al., 2002). The OLS result is shown in Table 2.

Table 2. The OLS Results

Model	Unstandardized Coefficients		Standardized Coefficients	t	Sig.
	B	Std. Error	Beta		
1 (Constant)	3.658	.502		7.285	.000
X1	.254	.132	.095	1.927	.054
X2	-.037	.121	-.014	-.309	.758
X3	-.104	.051	-.078	-2.036	.042
X4	-.272	.122	-.108	-2.230	.026
X5	.045	.090	.022	.499	.618
X6	-.346	.075	-.186	-4.605	.000
X7	.124	.087	.055	1.426	.154

a. Dependent Variable: Productivity

## 5. Conclusion

It can be concluded that (1) there are three industries that potentially have higher productivity in supporting the regional economy in South Sumatera, Indonesia. Those three potential industries are Food, Beverages and Tobaccos Industry, Other Processing Industry, and Textile, Clothes and Leather Industry. OKU Timur Regency, MUBA Regency and OKU Selatan Regency have high productivity and potential in the sector of Food, Beverages and Tobaccos Industry. Palembang City, Banyuasin Regency and Muara Enim Regency have high productivity and potential in the sector of Other Processing Industry. Meanwhile, Ogan Ilir Regency, Pagaralam City and OKU Induk Regency have high productivity and potential in the sector of Textile, Clothes and Leather Industry. The local and regional government should be more responsive to stimulate all the three industries in the region. The result also reveals that raw materials, local products which have the characteristics of the local area, the guarantee of raw material availability, and economic profitability have a significant impact

on micro and small business enterprises' productivity. Furthermore, the result is in line with the notion that a potential product of one region is determined by the local contents of raw materials; the more local contents of one product, the higher the potentiality of that product.

## References

- Abor, J., & Biekpe, N. (2006). SMEs' access to debt finance: A comparison of male-owned and female-owned businesses in Ghana. *International Journal of Entrepreneurship and Innovation*, 7(2): 105-112.
- Ang, J.S. (1991). Small business uniqueness and the theory of financial management. *Journal of Small Business Finance*, 1(1): 1-13.
- Aryeetey, E., Baah-Nuakoh, A., Duggleby, T., Hettige, H., & Steel, W. F. (1994). Supply and Demand for Finance of Small Scale Enterprises in Ghana. *Discussion Paper No. 251*, World Bank, Washington.
- Banerjee, A. V., & Duflo, E. (2004). Do firms want to borrow more? Testing credit constraints using a directed lending program. *CEPR Discussion Paper 4681*, Centre for Economic Policy Research, London.
- Banerjee, A., Duflo, E., Glennerester, R., & Kinnan, C. (2009). The miracle of microfinance? Evidence from a randomized evaluation. *Working Paper*, The Abdul Latif Jameel Poverty Action Lab at MIT and the Center for Microfinance at IFMR, Cambridge.
- Basyith, A., Idris, M., & Fitriya, F. (2014). Do the financing types from microfinance affect the SMEs' firm performance? Evidence from South Sumatera, Indonesia. *Journal of Global Business Issues*, 8(1): 81-95.
- Beck, T., & Demirgüç-Kunt, A. (2006). Small and medium-size enterprises: Access to finance as growth constraint. *Journal of Banking and Finance*, 30: 2931-2943
- Beck, T., Demirgüç-Kunt, A., Laeven, L., & Levine, R. (2008). Finance, firm size and growth. *Journal of Money, Credit, and Banking*, 40(7): 1379–1405.
- Beck, T., Demirgüç-Kunt, A., Laeven, L., & Maksimovic, V. (2006). The determinants of financing obstacles. *Journal of International Money and Finance*, 25(6): 932–952.
- Beck, T., Demirgüç-Kunt, A., & Maksimovic, V. (2005). Financial and legal constraints to firm growth: Does size matter? *Journal of Finance*, 60(1): 137–177.
- Beck, T., Demirgüç-Kunt, A., & Peria, M. (2008). Banking services for everyone? Barriers to bank access and use around the world. *The World Bank Economic Review*, 22(3): 397–430.

- Berger, A. N., & Udell, G. F. (1998). The economics of small business finance: The roles of private equity and debt markets in the financial growth cycle. *Journal of Banking and Finance*, 22(6-8): 613-673.
- Brewer, E. III. (2007). On lending to small firms. *Journal of Small Business Management*, 45(1): 42-46.
- Carpenter, R., & Petersen, B.C. (2002). Is the growth of small firms constrained by internal finance? *Review of Economics and Statistics*, 84(2): 298-309
- Chaia, A., Dalal, A., Goland, T., Gonzalez, M., Morduch, J., & Schiff, R. (2009). *Half the world is unbanked*. Financial Access Initiative. Available at: <http://financialaccess.org/research/publications>
- Claessens, S., & Laeven, L. (2004). What drives bank competition? Some international evidence. *Journal of Money, Credit, and Banking*, 36(3): 563–582.
- Demirgüç-Kunt, A., & Maksimovic, V. (1998). Law, finance, and firm growth. *Journal of Finance*, 53(6): 2107–2137.
- Fisher, E., & Reuber, R. (2000). Industrial clusters and SME promotion in developing countries. *Commonwealth Trade and Enterprise Paper No. 3*.
- Gine, X., & Karlan, D. (2008). Peer monitoring and enforcement: Long term evidence from microcredit lending groups with and without group liability. *Yale University Working Paper*, New Haven.
- Green, C. J., Kimuyu, P., Manos, R., & Murinde, V. (2002). How do Small Firms in Developing Countries Raise Capital? Evidence from a Large-Scale Survey of Kenyan Micro and Small Scale Enterprises, *Economic Research Paper No. 02/6*, Centre for International, Financial and Economics Research, Department of Economics, Loughborough University.
- Hadjimanolis, A. (1999). Barriers to innovation for SMEs in a small less developed country (Cyprus), *Technovation*, 19(9): 561-570.
- Hasbullah, R., Surahman, M., Yani, A., Almada, D. P., & Faizaty, E. N. (2014). Model pendampingan UMKM pangan melalui incubator bisnis perguruan tinggi. *Jurnal Ilmu Pertanian*, 19(1): 43-49.
- Karlan, D. (2007). Social connections and group banking. *The Economic Journal*, 117(517): 52–84.
- Kayanula, D., & Quartey P. (2000), The policy environment for promoting small and medium-sized enterprises in Ghana and Malawi. *Working Paper Series Paper No. 15*, IDPM, University of Manchester.

- Keasey, K., & Watson, R. (1987). Non-financial symptoms and the prediction of small company failure. *Journal of Business Finance & Accounting*, 14(3): 335- 354.
- Klapper, L., Laeven, L., & Rajan, R. (2006). Entry regulation as barrier to entrepreneurship. *Journal of Financial Economics*, 82(3): 591–629.
- Lader, P. (1996). The public/private partnership. *Springs Spring*, 35(2): 41-44.
- Lantu, D. C., Triady, M.S., Utami, A. F., & Ghazali, A. (2016). Pengembangan model peningkatan daya saing UMKM di Indonesia: Validating kuantitatif modal. *Jurnal Manajemen Teknologi*, 15(1): 77-93.
- Levy, B. (1993). Obstacles to developing indigenous small and medium enterprises: An empirical assessment. *The World Bank Economic Review*, 7(1): 65-83.
- Levy, P. S., & Lemeshow, S. (2008). *Sampling of Populations: Methods and Applications*, 4<sup>th</sup> Ed. New Jersey: John Wiley & Sons, Inc.
- Love, I. (2003). Financial development and financing constraints: International evidence from the structural investment model. *Review of Financial Studies*, 16(3): 765–791.
- Pettit, R.R., & Singer, R.F. (1985). Small business finance: A research agenda. *Financial Management*, 14(3): 47-60.
- Portes, A. (1998). Social capital: Its origins and applications in modern sociology. *Annual Review of Sociology*, 24: 1–24.
- Rajan, R., & Zingales, L. (1998). Financial dependence and growth. *American Economic Review*, 88(3): 559–587.
- Ravikiran, B. S., & Vittal, C. B. V. (2015). Role of Vital Factors for the Success of Products of Small Entrepreneurs, *International Journal of Modern Engineering Research*, 2(1): 16-20.
- Schmitz, H. (1995). Collective efficiency: Growth path for small scale industry, *The Journal of Development Studies*, 31(4): 529-566.
- Smith-Doerr, L., & Powell, W. (2005). Networks and economic life. In N. Smelser, & R. Swedberg (Eds.), *Handbook of economic sociology* (pp. 377–402). New York: Russell Sage Foundation.
- Steiner, M. P., & Olaf, S. (1988). Factors for success in small manufacturing firms, *Journal of Small Business Management*, 26(1): 51- 56.
- Susilo, S., Hubeis, M., & Purwanto, B. (2012). Pengaruh karakteristik dan perilaku UKM, serta system pembiayaan terhadap penyalulran pembiayaan BNI syariah. *Manajemen IKM*, 7(1): 1-9.

Wurgler, J. (2000). Financial markets and the allocation of capital. *Journal of Financial Economics*, 58(1-2): 187-214.